

Outdoor Rack

Elite Safe Outdoor Series



07511100599
07705860252



sales@electro-dsign.com



Erbil, Makhmoor Road, Near Qoritan

OUTDOOR RACK

Industrial Waterproof Enclosure



Model: 12 Unit / Wallmounted

KEY FEATURES

- Waterproof outdoor design
- Heavy-duty steel construction
- Powder coated
- Lockable front door
- Ventilation system
- Dust & water resistant
- Industrial grade durability

TECHNICAL SPECIFICATIONS

Dimensions (W×H×D)	600*650*500mm
Material	Galvanized Plate
Thickness	1.2mm
Paking	Yes
Color	RAL 7035
IP Rating	IP 55
Operating Temperature Range	-10 ° to +45 °
Cooling System	Fan/Filter/Thermostat

OPTIONAL ACCESSORIES

- Cooling fan
- Thermostat
- Heater
- Air filter
- Stand Base
- Mounting base
- Custom color
- Custom size
- Thermal Insulation
- Internal Rack Lighting
- PDU

COMPANY INFORMATION

Company: **Electro Design**

Website: **www.electro-dsign.com**

Email: **Sales@electro-dsign.com**

Phone: **07511100599 / 07705860252**

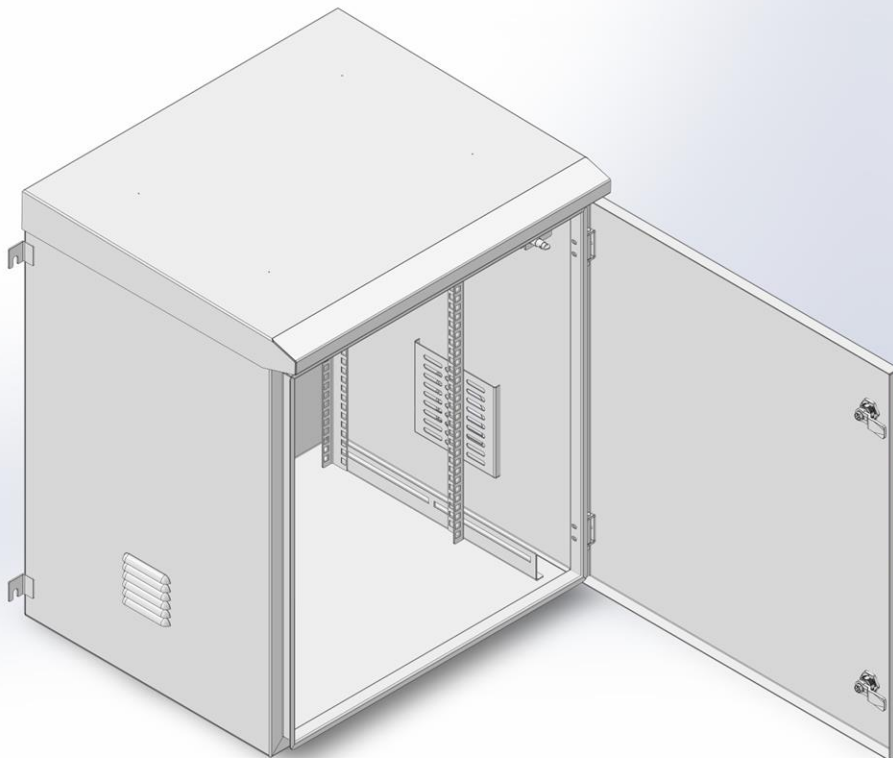
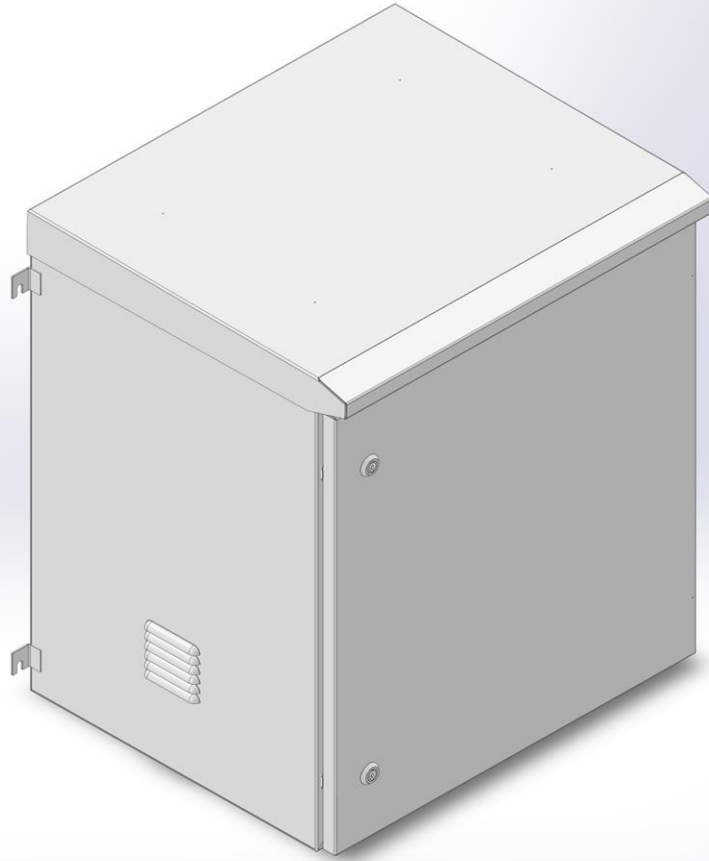

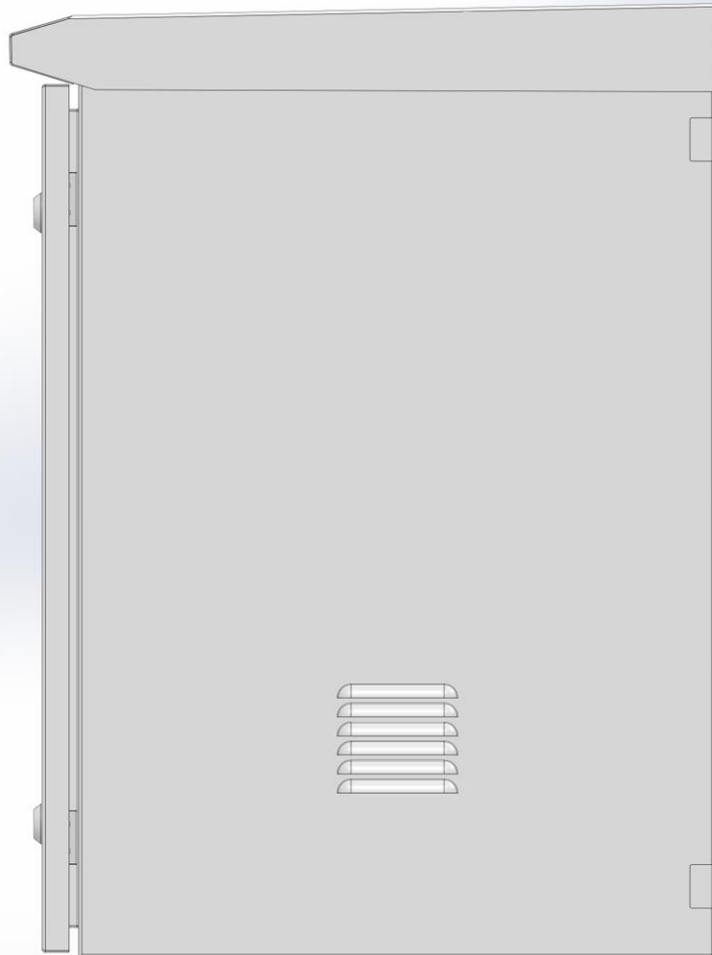
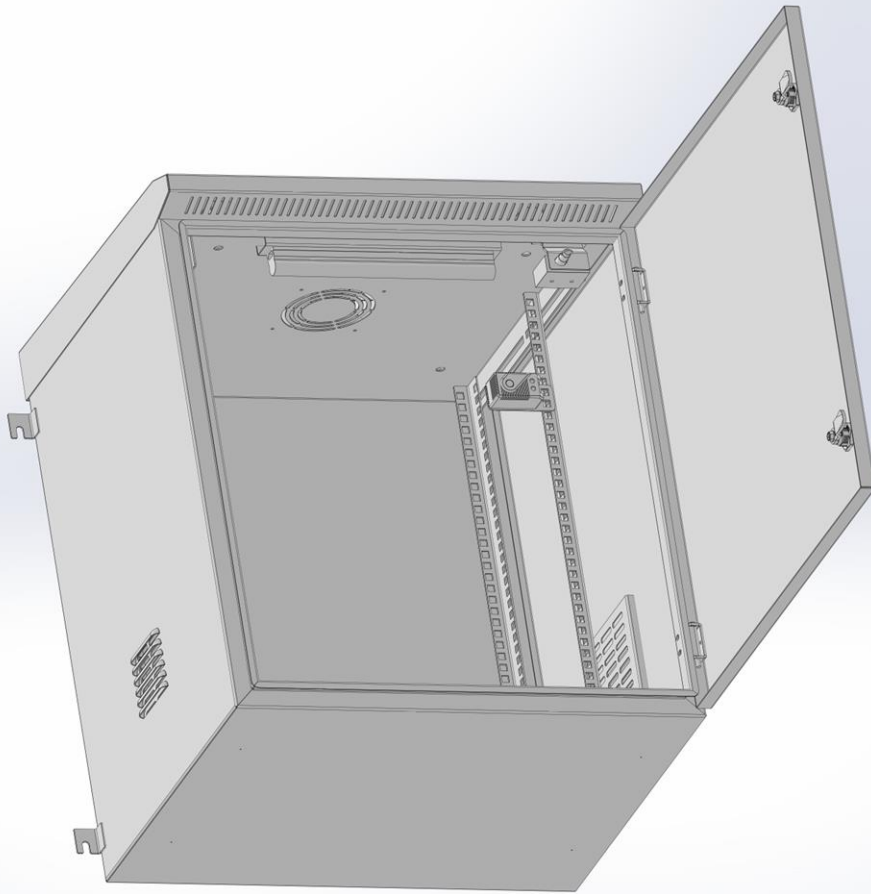

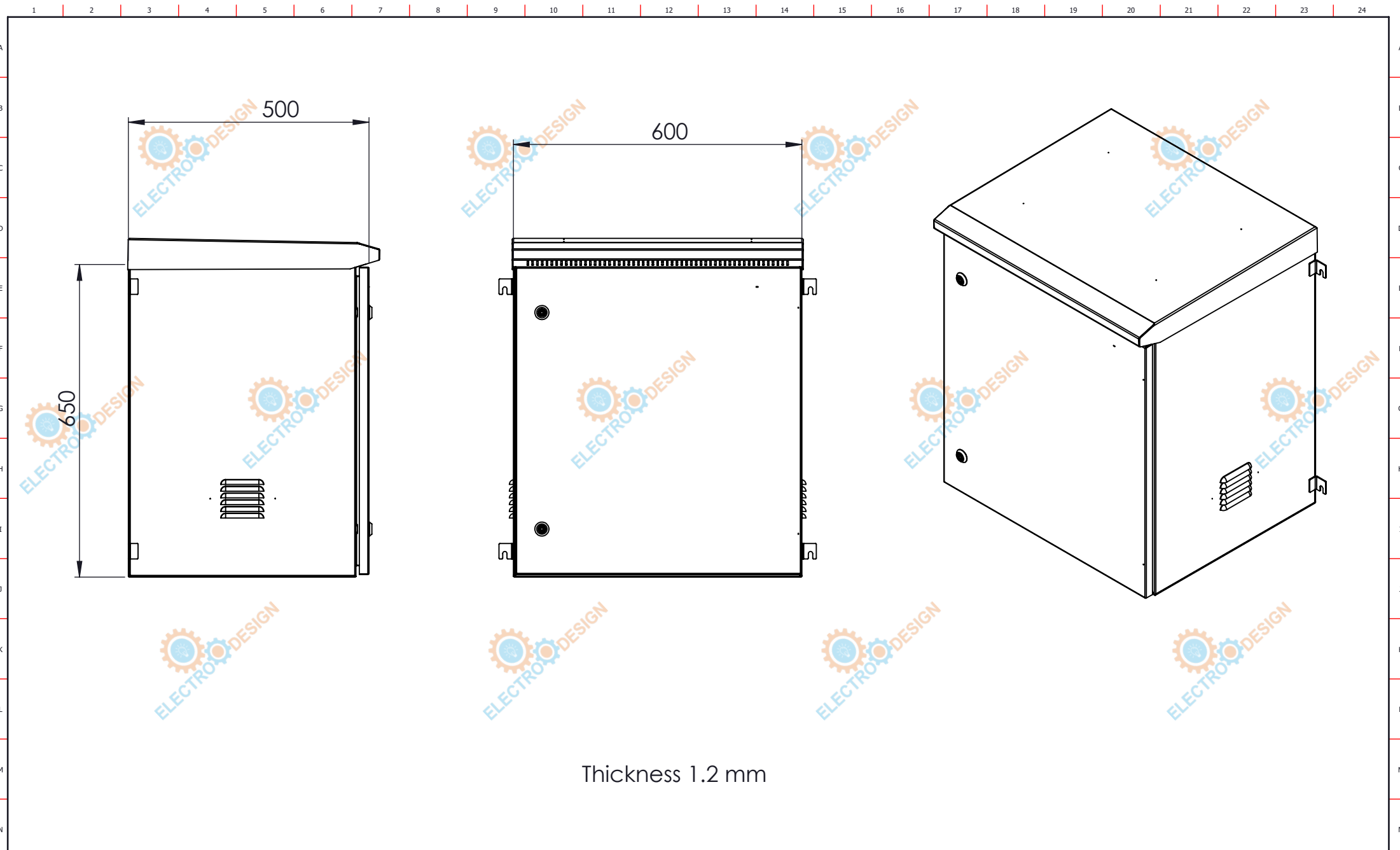

Thickness 1.2 mm

					Contractor:	Client :	Design		Project Name:	Contractor Project Number:
							Drawn			Client Project Number:
							Checked			Switchgear Name :
					Website:	Consultant:	Approved		Title:	
					E-mail:		Date		Page Title:	Number of Cubicle:
REV	Date	Revision Description	Revised	Approved	Tel:		Rev			Page Number:
							Format:	Scale: N.T.S		Total Sheet :

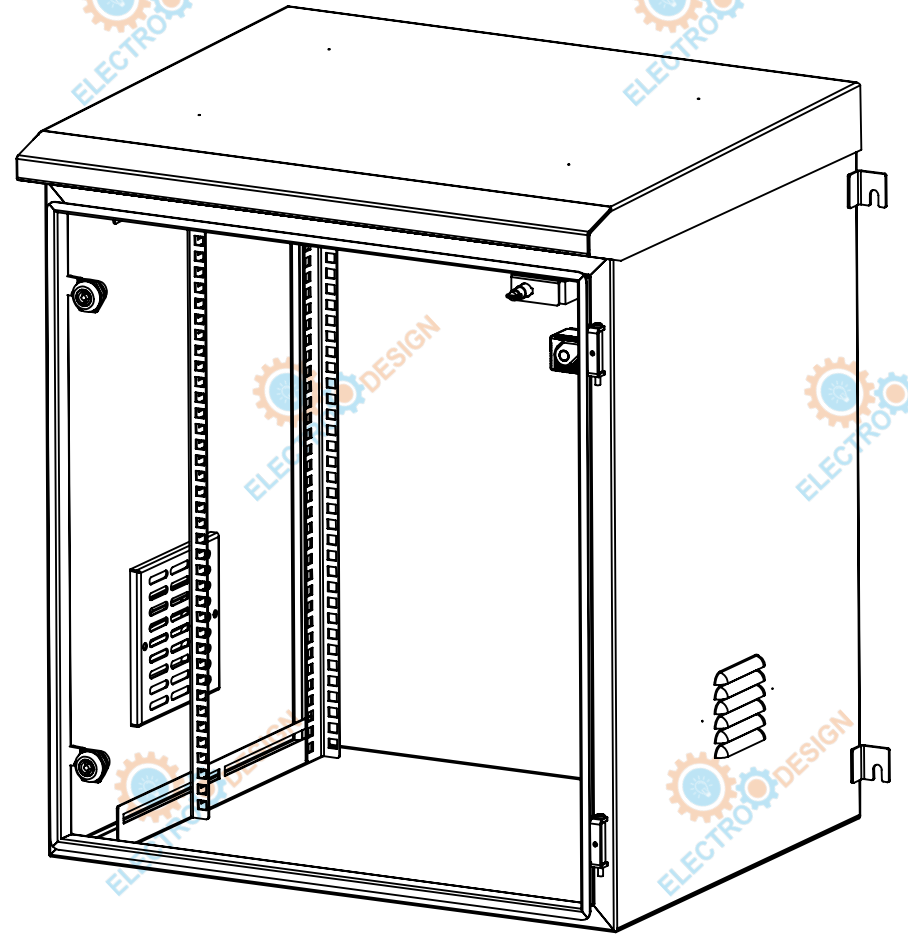
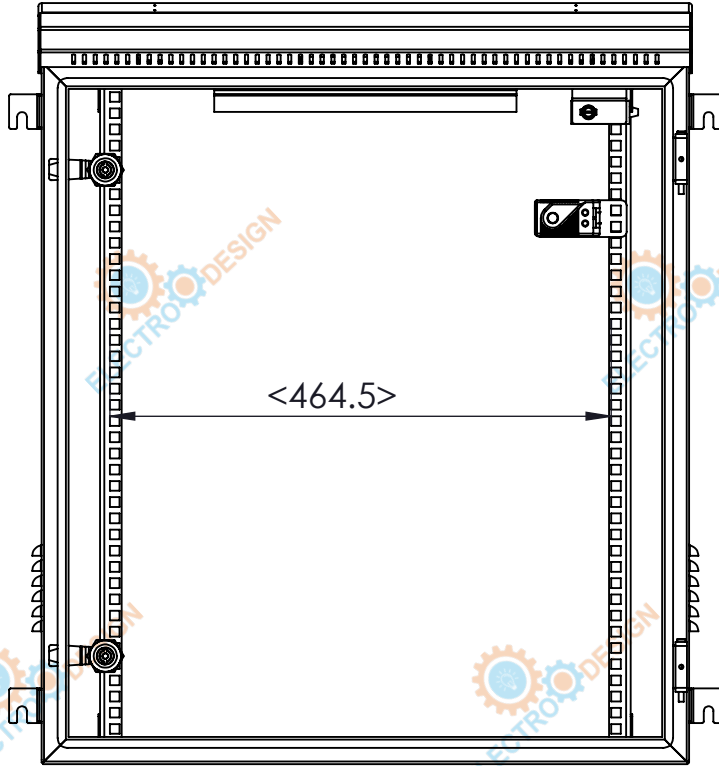

					Contractor:	Client :	Design		Project Name:	Contractor Project Number:	
							Drawn			Client Project Number:	
							Checked			Switchgear Name :	
					Website:	Consultant:	Approved		Title:		
					E-mail:		Date		Page Title:	Number of Cubicle:	
REV	Date	Revision Description	Revised	Approved	Tel:		Rev			Page Number:	Total Sheet :
							Format:	Scale: N.T.S			

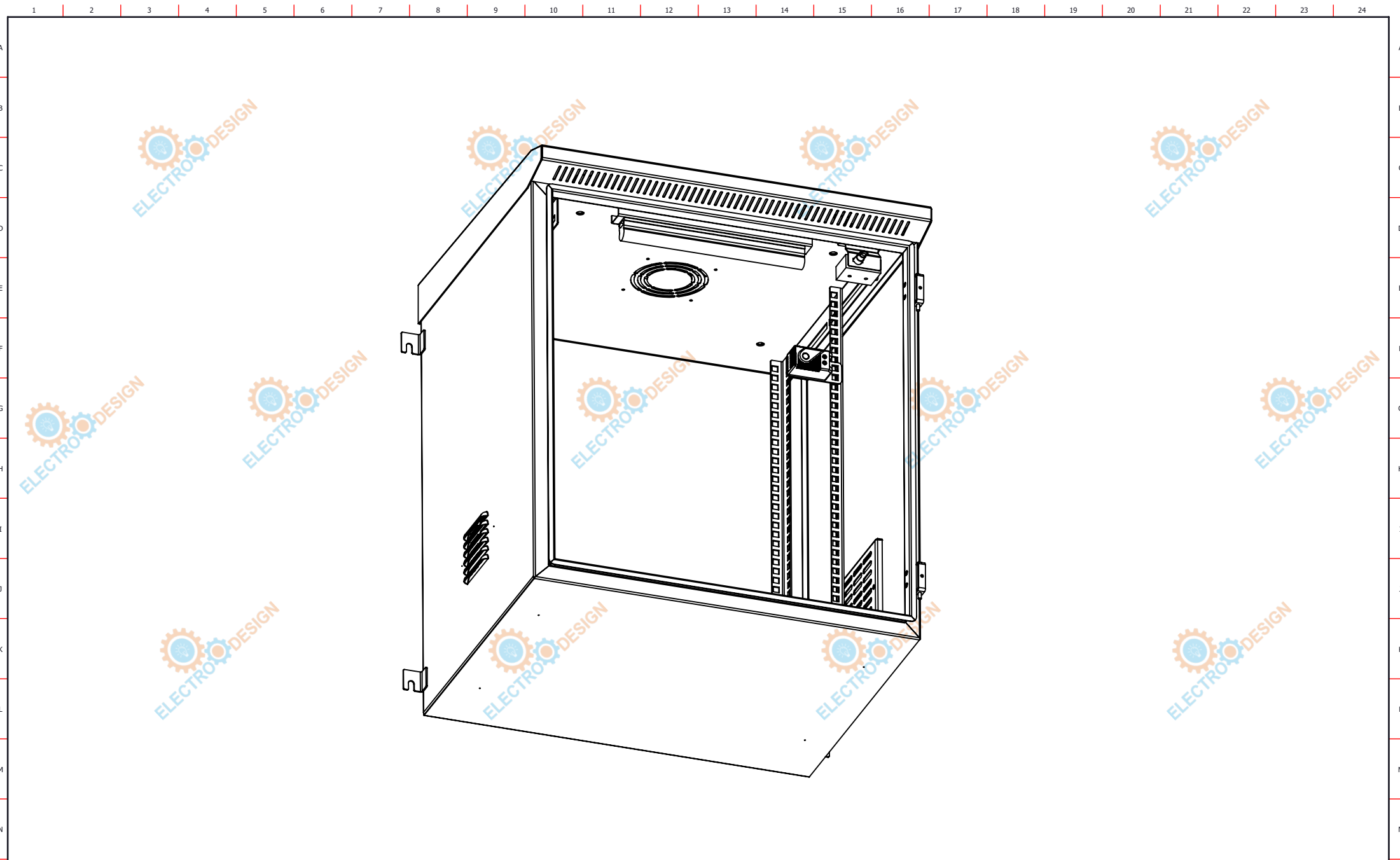

					Contractor:  ELECTRO DESIGN Website: https://www.electro-dsign.com E-mail: info@electro-dsign.com Tel: +9647511100599/Sales and Marketing +9647511100499/Technical	Client : Consultant:	Design Drawn Checked Approved Date Rev Format:	Project Name: Title: Page Title:	Contractor Project Number: Client Project Number: Switchgear Name : Number of Cubicle: Page Number:	Total Sheet :
REV	Date	Revision Description	Revised	Approved			Scale: N.T.S			